

OAK VALLEY SPACE QB

Grab & Go

33 - 50°F
1 - 10°C



Climatic class 3H
Humidity 60%
Ambient temp +25°C
Air speed 0,2m/sec



Multi-level self-service refrigerated counter



Contact Us
Phone: (347) - 809 3544 Email: contact@rimacold.com

OAK VALLEY SPACE QB



Grab & Go

33 - 50°F
1 - 10°C

Climatic class 3H
Humidity 60%
Ambient temp +25°C
Air speed 0,2m/sec

OAK VALLEY SPACE QB H2

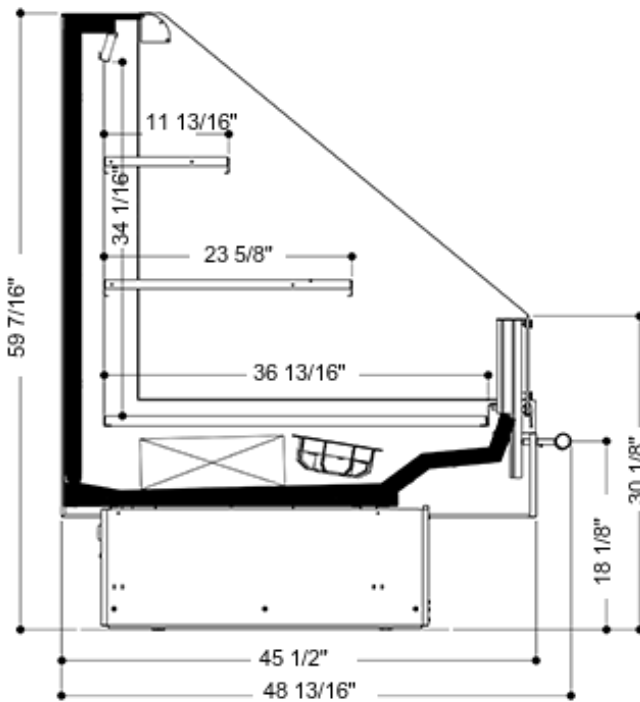

Oak Valley Space QB H1 / H2 is a multi-level self-service refrigerated counter that provides excellent visibility for any refrigerated product that you want your customers to select themselves. Available with two to three display levels and several lengths, this cabinet ensures convenient shopping and is an attractive option for retail stores. Great for displaying pre-packed meat, poultry, seafood products, cheeses, and pastries. Multiplexable with other OAK VALLEY SPACE QB counters.

NOTE: We reserve the right to change or revise specifications and product design in connection with any feature of our products. Such changes do not entitle the buyer to corresponding changes, improvements, additions, or replacements for equipment previously sold or shipped.



Contact Us
Phone: (347) - 809 3544 Email: contact@rimacold.com

OAK VALLEY SPACE QB



Grab & Go

33 - 50°F
1 - 10°C

Climatic class 3H
Humidity 60%
Ambient temp +25°C
Air speed 0,2m/sec

OAK VALLEY SPACE QB H1



Product images are for illustrative purposes only and may differ from the actual product of the latest design.

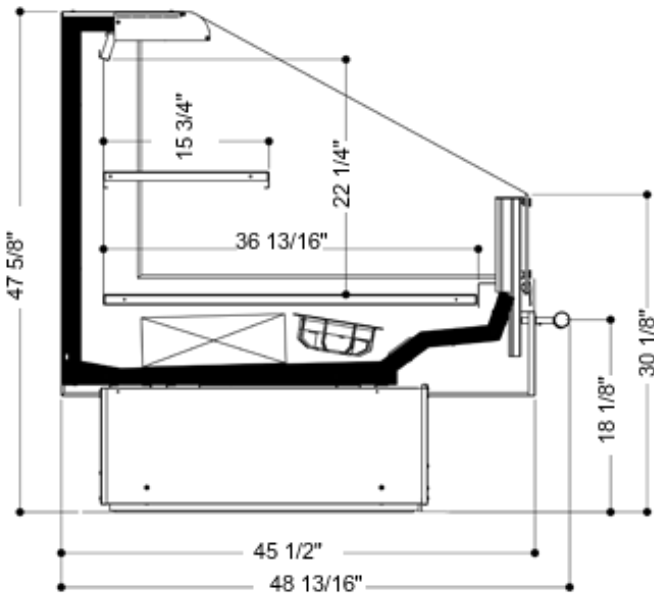

NOTE: We reserve the right to change or revise specifications and product design in connection with any feature of our products. Such changes do not entitle the buyer to corresponding changes, improvements, additions, or replacements for equipment previously sold or shipped.



Contact Us
Phone: (347) - 809 3544 Email: contact@rimacold.com

OAK VALLEY SPACE QB



Grab & Go

33 - 50°F
1 - 10°C

Climatic class 3H
Humidity 60%
Ambient temp +25°C
Air speed 0,2m/sec



STANDARD

- Enlarged display surface
- Stainless-steel bumper
- Shelves (one shelf for H1 and two shelves for H2)
- Multiplexible device
- Strong tempered glass
- Panoramic endwalls
- Protection against glass fogging
- Possibility to lift the bottom of the counter to clean and tidy it
- Wide choice of colors for the exterior and interior (RAL palette)
- Even allocation of cool air throughout the whole area
- Energy saving electronically commutated fans
- Electronic control panel
- Thermometer (solar powered or electronic)
- Polyurethane thermal insulation CFC free.

Accessories

- Price holder.
- Low plexiglass divider.

Options

- LED lighting
- Galvanized steel or stainless-steel display surface
- Electric defrost heater.



RIMASEE



Contact Us

Phone: (347) - 809 3544 Email: contact@rimacold.com