

RENO S/R

Serve-Over Counter

33°F ... 50°F

30°F ... 44°F

30°F ... 41°F



Climatic class H1/M2/M1

Humidity 60%

Ambient temp 77°F

Air speed 0,2m/sec

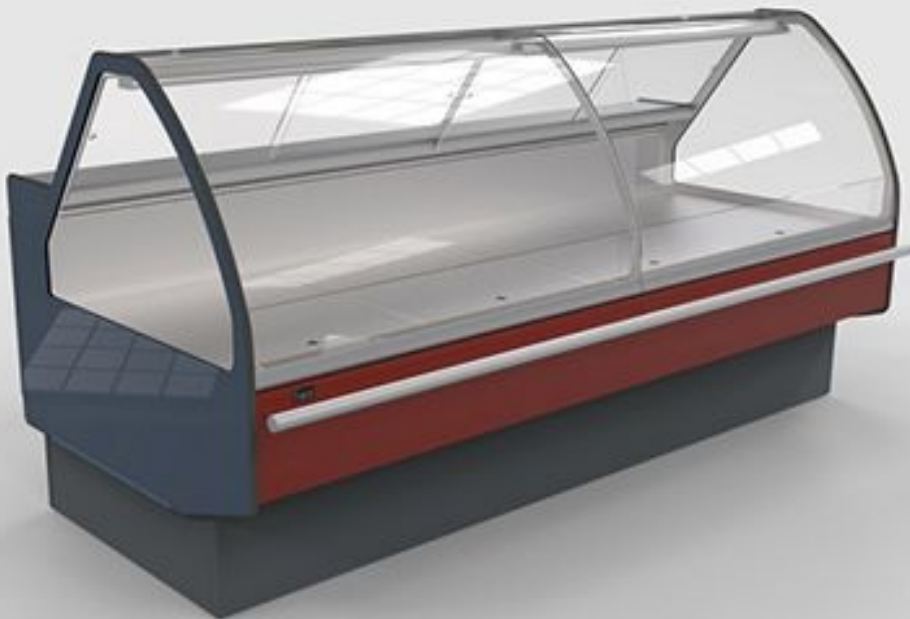

Curved front glass serve over counter



Contact Us

Phone: (347) - 809 3544 Email: contact@rimacold.com

RENO S/R

Serve-Over Counter

33°F ... 50°F

30°F ... 44°F

30°F ... 41°F



Climatic class H1/M2/M1

Humidity 60%

Ambient temp 77°F

Air speed 0,2m/sec

This is a refrigerated serve-over counter with an additional refrigerated storage capacity with doors from the back of the counter. With an enlarged display area, the RENO S/R offers ample space for the display of merchandise, also a wide range of accessories. It provides stable temperature performance and optimal storage environment for meats, poultry, dairy, and other products.

The harmonious and stylish design with smooth rounded glass underlines the attractiveness of products displayed and makes the RENO S/R an ideal solution for any store or food market.

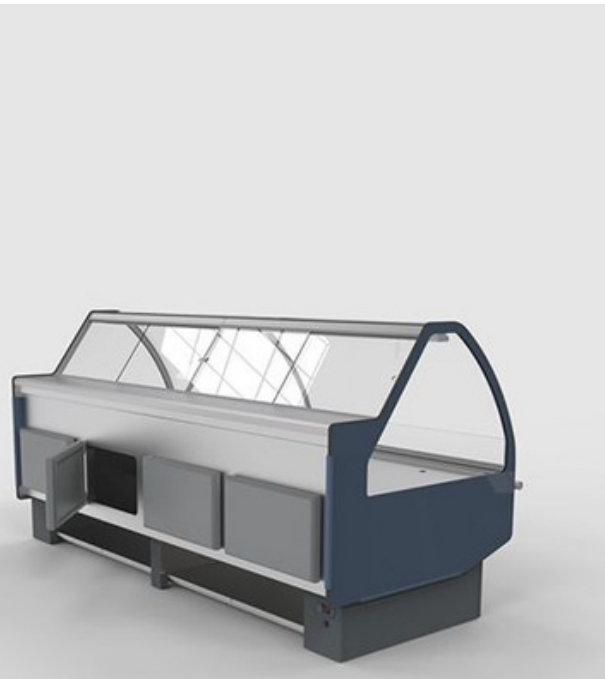

Curved front glass serve over counter



Contact Us

Phone: (347) - 809 3544 Email: contact@rimacold.com

RENO S/R

Serve-Over Counter

33°F ... 50°F

30°F ... 44°F

30°F ... 41°F



Climatic class H1/M2/M1

Humidity 60%

Ambient temp 77°F

Air speed 0,2m/sec

Standard

- Sturdy stainless steel display surfaces and interior details
- Stainless steel front protection
- Multiplexible device
- Canopy lighting
- Strong tempered glass
- Lifiable front glass
- Panoramic sides for optimal visibility
- Exterior colour – any of RAL palette
- Possibility to lift the bottom of the counter to clean and tidy it
- Even allocation of cool air throughout the whole area
- Thermometer (solar powered or electronic)
- Electronic control panel
- Energy saving electronically commutated fans
- Polyurethane thermal insulation CFC free.

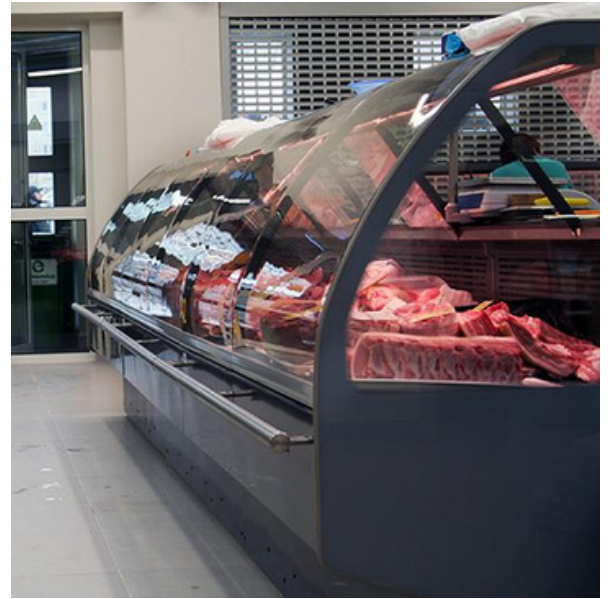

Accessories

- High plexiglass divider
- Low plexiglass divider
- Plastic scale platform
- Plastic cutting board
- Trays of stainless steel
- Paper roll holder
- Knives holder.

Options

- Back doors for energy saving
- Electric defrost heater.

Curved front glass serve over counter



Contact Us

Phone: (347) - 809 3544 Email: contact@rimacold.com

RENO S/R

Serve-Over Counter

33°F ... 50°F

30°F ... 44°F

30°F ... 41°F



Climatic class H1/M2/M1

Humidity 60%

Ambient temp 77°F

Air speed 0,2m/sec

Available Lengths without end walls: 4', 6', 8', 12'

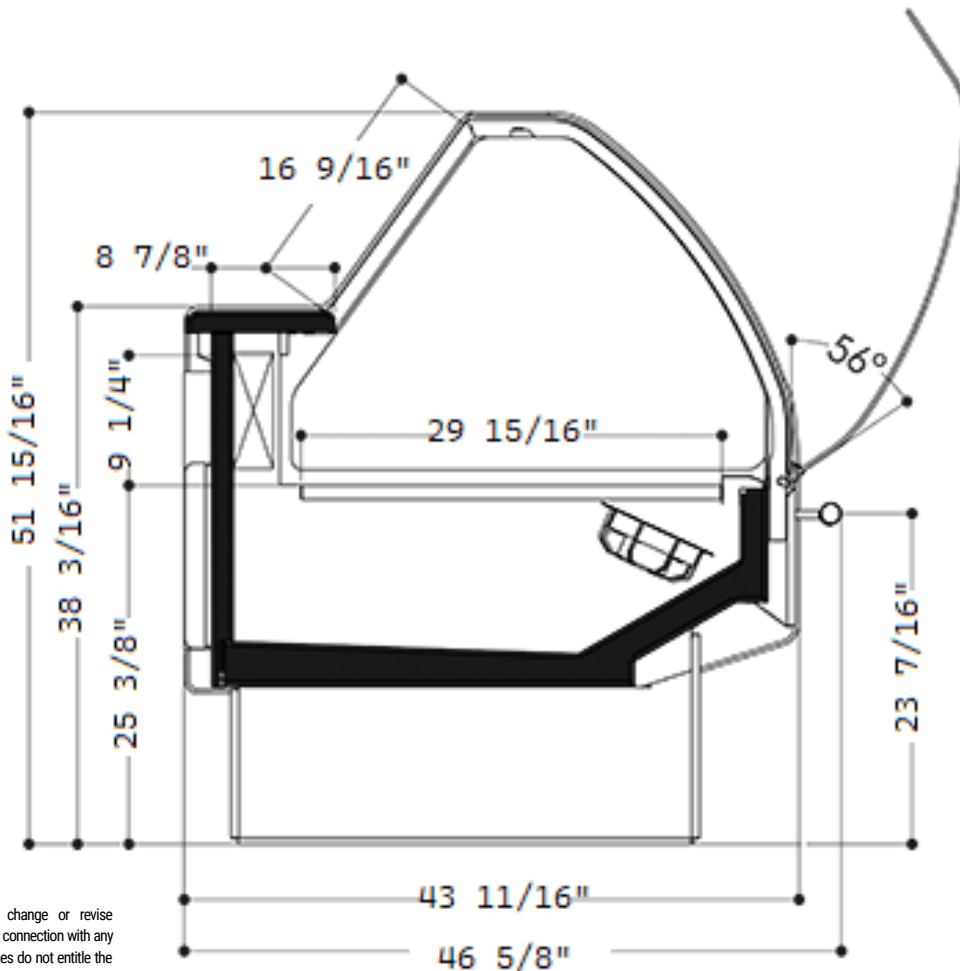

NOTE: We reserve the right to change or revise specifications and product design in connection with any feature of our products. Such changes do not entitle the buyer to corresponding changes, improvements, additions, or replacements for equipment previously sold or shipped.

RENO S/R

Curved front glass serve over counter



RIMASEE



Contact Us

Phone: (347) - 809 3544 Email: contact@rimacold.com