

# ALASKA DUO

## Plug In Bunker

3.2°F ... -7.6°F



Climatic class 3L1  
Humidity 60%  
Ambient temp 77°F  
Air speed 0,2m/sec



Low Temperature Bunker With Sliding Doors

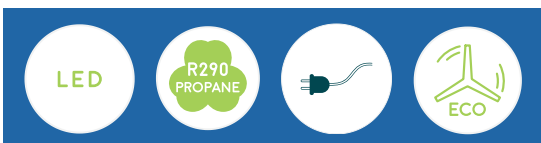

RIMASEE



Contact Us

Phone: (347) - 809 3544 Email: sales@rimasee.com

# ALASKA DUO

## Plug In Bunker

3.2°F ... -7.6°F



Climatic class 3L1  
Humidity 60%  
Ambient temp 77°F  
Air speed 0,2m/sec

		Alaska DUO 2200 DE	Alaska DUO 2200 DEPN
<b>Technical Data</b>			
Total Display Area (TDA)	ft <sup>2</sup>	29.06	29.06
Climatic Class (EN23953)		3L1	3L1 & 3M1
Temperature Range	°F	3/-7.6	-7.6/10
Maintenance free condenser		Yes	Yes
Visual Alarm		Yes	Yes
HACPP - Hazrd analysis and critical control points		Yes	Yes
Surveillance System		No	No
Net Volume	Qt	1326	1326.5
Gross Volume	Qt	1793.2	1793.2
<b>Electrical Data</b>			
Voltage / Frequency	V/Hz	220-110/60	220-110/60
Rated Power	W	522	716
Rated Current	Amps	2.5	5.8
Energy Consumption	kWh/24h	9.2	9.15(-)/3.8(+)
Energy Efficiency Index (EEI)		24.70	26.70
<b>Refrigerant Data</b>			
Refrigerant Type		R290	R290
Number of Compressors		2	2
Maximum Operating Pressure	bar	30	30
<b>Dimensions and Weight Data</b>			
Cabinet Dimensions	inches	84 5/8" x 57 11/16" x 36 5/8"	84 5/8" x 57 11/16" x 36 5/8"
Packaging Dimensions	inches	88 3/16" x 61 " x 41 5/16"	88 3/16" x 61 " x 41 5/16"
Net Weight	lbs	437	437
Gross Weight	lbs	553.4	553.4

Introducing the Alaska DUO freezer bunker - the perfect blend of style and efficiency. With stunning front and double exposure, this bunker is a must have for any establishment looking to display better, save on energy and maintenance cost. It features a variable speed compressor for optimal performance and energy savings. The interior and exterior are constructed with high quality galvanized sheet metal, coated in PVC to meet food regulations. The entire cold circuit is made of copper, ensuring long lasting durability. The Alaska DUO boasts, LED lighting with automatic control, automatic defrosting, water evaporation and a maintenance free condenser and possibility of customization.



NOTE: We reserve the right to change or revise specifications and product design in connection with any feature of our products. Such changes do not entitle the buyer to corresponding changes, improvements, additions, or replacements for equipment previously sold or shipped.

Low Temperature Bunker With Sliding Doors

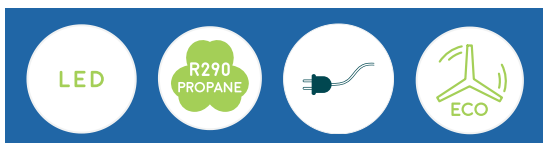

Contact Us

Phone: (347) - 809 3544 Email: sales@rimasee.com

# ALASKA DUO

## Plug In Bunker

3.2°F ... -7.6°F



Climatic class 3L1  
Humidity 60%  
Ambient temp 77°F  
Air speed 0,2m/sec

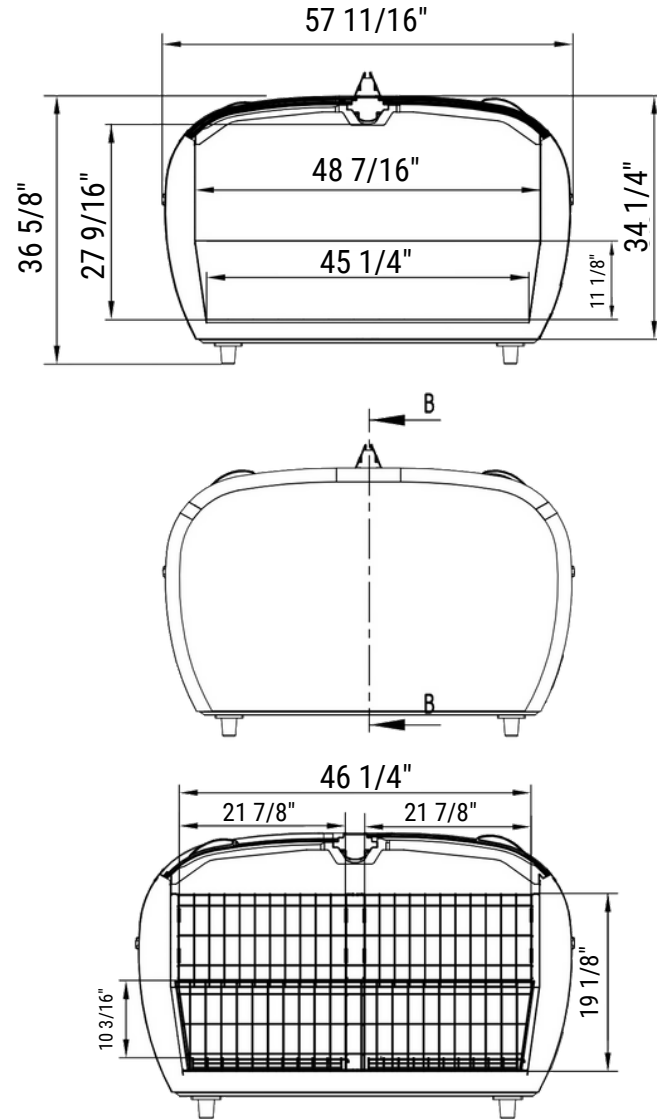
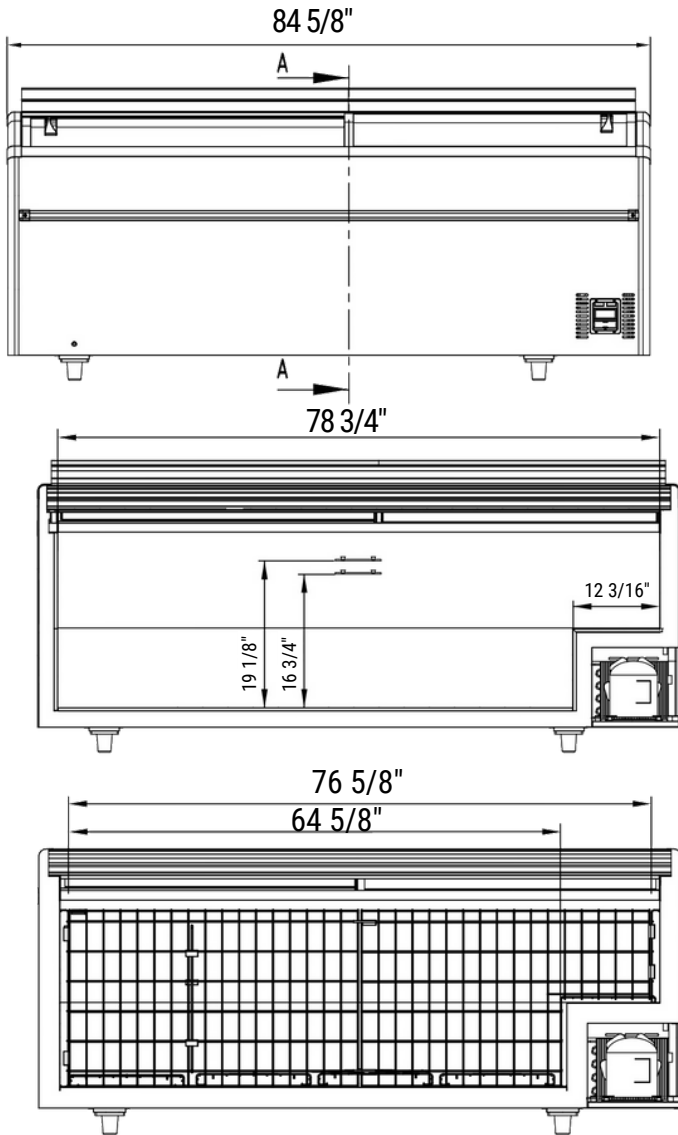

NOTE: We reserve the right to change or revise specifications and product design in connection with any feature of our products. Such changes do not entitle the buyer to corresponding changes, improvements, additions, or replacements for equipment previously sold or shipped.

Low Temperature Bunker With Sliding Doors

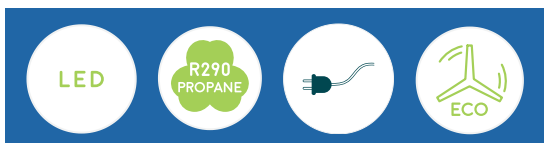

Contact Us

Phone: (347) - 809 3544 Email: sales@rimasee.com