

RIMA L080SS

Grab & Go - Low Profile Case

36 - 40°F



Climatic Class 3M2
Humidity 55%
Ambient temp 75°F
Air speed 0,2m/sec



**Self Contained Refrigerated Grab & Go
Low Profile Case**



RIMASEE



Contact Us

Phone: (347) - 809 3544 Email: sales@rimasee.com

RIMA L080SS

Grab & Go - Low Profile Case



36 - 40°F

Climatic Class 3M2
Humidity 55%
Ambient temp 75°F
Air speed 0,2m/sec

STANDARD FEATURES

- Silver colored PVC coated steel front panel
- Pull down night curtain
- CFC free injected foam insulation
- PVC coated steel gray interior
- Black steel kick plate
- Foamed polystyrene black end panels
- Tempered side glass
- Height adjustable shelves can be tilted
- Products stop on shelves
- Temperature and defrost regulated by a digital controller
- Digital thermometer
- Slide out condensing unit on self-contained units
- Removable condensate evaporating pan for easy cleaning on self contained units
- Cord and plug RIMA L080SS_100 only
- Leveling feet

OPTIONAL FEATURES

- Stainless steel exterior and / or interior
- Other colors available
- Additional shelves
- Price tag molding
- Joining kit Partition or product dividers
- Condensate evaporating pan for remote cases
- Casters-add 4-3/8" to height
- Stainless steel legs are adjustable from 5-1/8" to 7-5/8"

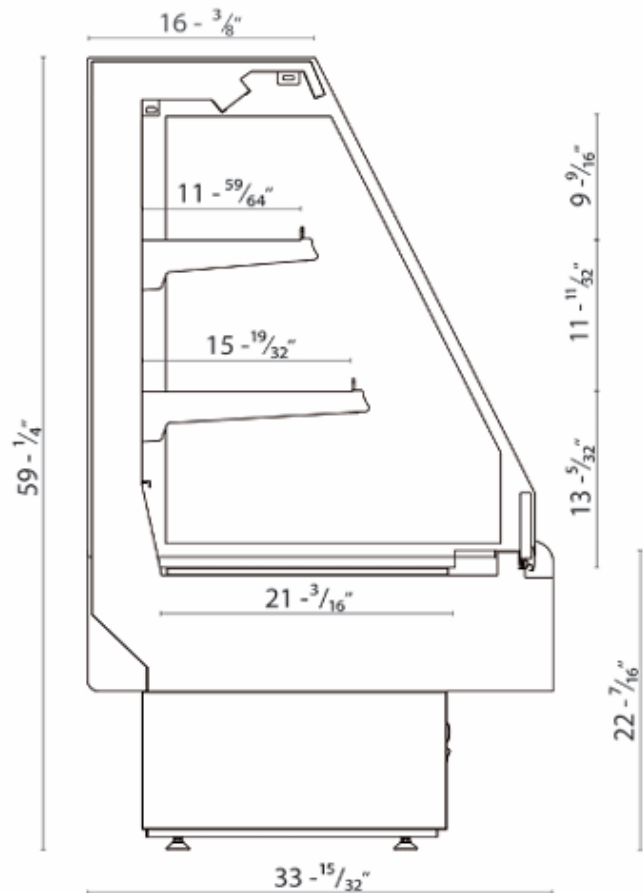

NOTE: We reserve the right to change or revise specifications and product design in connection with any feature of our products. Such changes do not entitle the buyer to corresponding changes, improvements, additions, or replacements for equipment previously sold or shipped.

Self Contained Refrigerated Grab & Go Low Profile Case

Standard Mounting



Levelling Feet

Optional Mounting



Adjustable Legs



Castors



RIMASEE



Contact Us

Phone: (347) - 809 3544 Email: sales@rimasee.com

RIMA L080SS

Grab & Go - Low Profile Case

36 - 40°F



Climatic Class 3M2
Humidity 55%
Ambient temp 75°F
Air speed 0,2m/sec

	Model	O.A. Length (inches)	Volume FT ³	Electrical 115V					NEMA 115 V Plug	Weights lbs		Crate Size Inches			
				Front	Compressor		Lights Fans	EVAP Pan		Total Amps	No Crate	With Crate	L"	W"	H"
					H.P	F.L.A									
Selfcontained	L080_SS25_100 S	41	12.98	5/8.	8.9	0.85	6.7	16.42	5 - 20P	357	507	43.8	34.5	67.8	
	L080_SS25_130 S	50.2	16.21	3/4.	16	1.33	6.7	24	-	394	369	53	34.5	67.8	
	L080_SS25_150 S	60.6	19.85	3/4.	16	1.39	6.7	24	-	454	653	63.5	34.5	67.8	

	Model	O.A. Length (inches)	Total Amps	B.T.U	Weights lbs	
					No Crate	With Crate
Remote	L080_SS25_100	41	0.4	4125	291	441
	L080_SS25_130	50.2	0.43	4897	317	491
	L080_SS25_150	60.6	0.49	5141	376	575



NOTE These cases are engineered to operate in locations not exceeding 75°F and 55% R.H. These cases are designed to operate using R290 refrigerant. Alternate refrigerants available by special order. O.A. length includes (2) ends at 1-1/2" each. Ventilation grills at front and back cannot be blocked. B.T.U.'s are calculated at 14°F (evaporator) and 90°F (ambient). Remote cases are provided with an expansion valve and a liquid solenoid for pump down cycle. On remote cases, if no floor drain is provided, a condensate evaporating pan must be ordered and 3.3 amps added to the amp load. Remote cases must be hard wired - no plugs.

Self Contained Refrigerated Grab & Go Low Profile Case



Contact Us

Phone: (347) - 809 3544 Email: sales@rimasee.com